

speed / Areameter 1100

1100 SPEED / AREAMETER

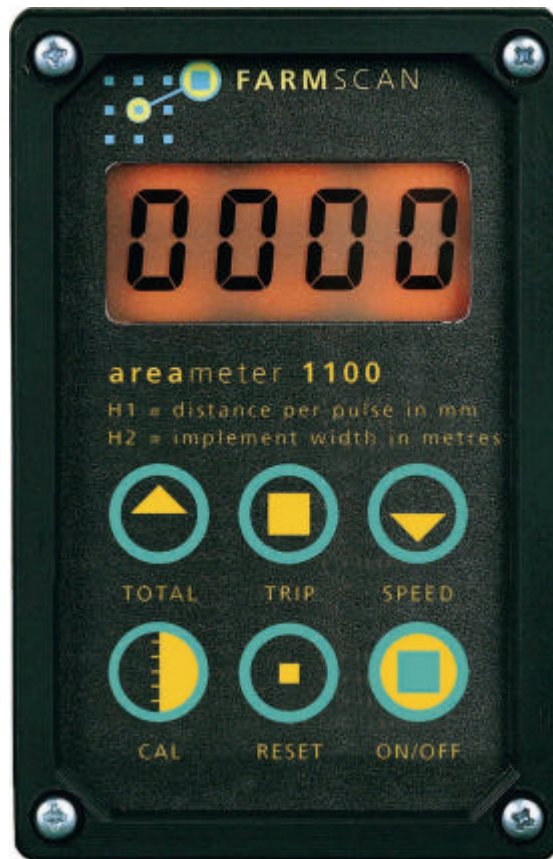

INSTALLATION AND OPERATION INSTRUCTIONS

VERSION 1.0

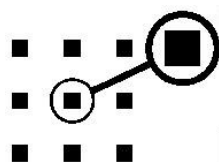

FARMSCAN

PART No: AM - 1100

COMPONENT LIST - 1100 AREAMETER KIT

REF	PART No.	DESCRIPTION	QTY
1	A-1100 / 2	AREAMETER UNIT	1
2	AH-409	MOUNTING BRACKET (small)	1
3	AH-861	SECURING KNOBS	2
4	AC-205	5m 2 WAY SENSOR CABLE	1
5	AH-400	CABLE MOUNTING BRACKET	1
6	AA-110C	REED TYPE SENSOR	1
7	AA-133	WHEEL MAGNET	1
8	AC-101	8m POWER CABLE	1
9	AH-408	UNIVERSAL HARDWARE PACK	1
10	AM-1100 / 2	1100 AREAMETER MANUAL (12V)	1
11	AM-200	WARRANTY REGISTRATION CARD	1
12	HG-706	CABLE TIES 290 x 5mm	10

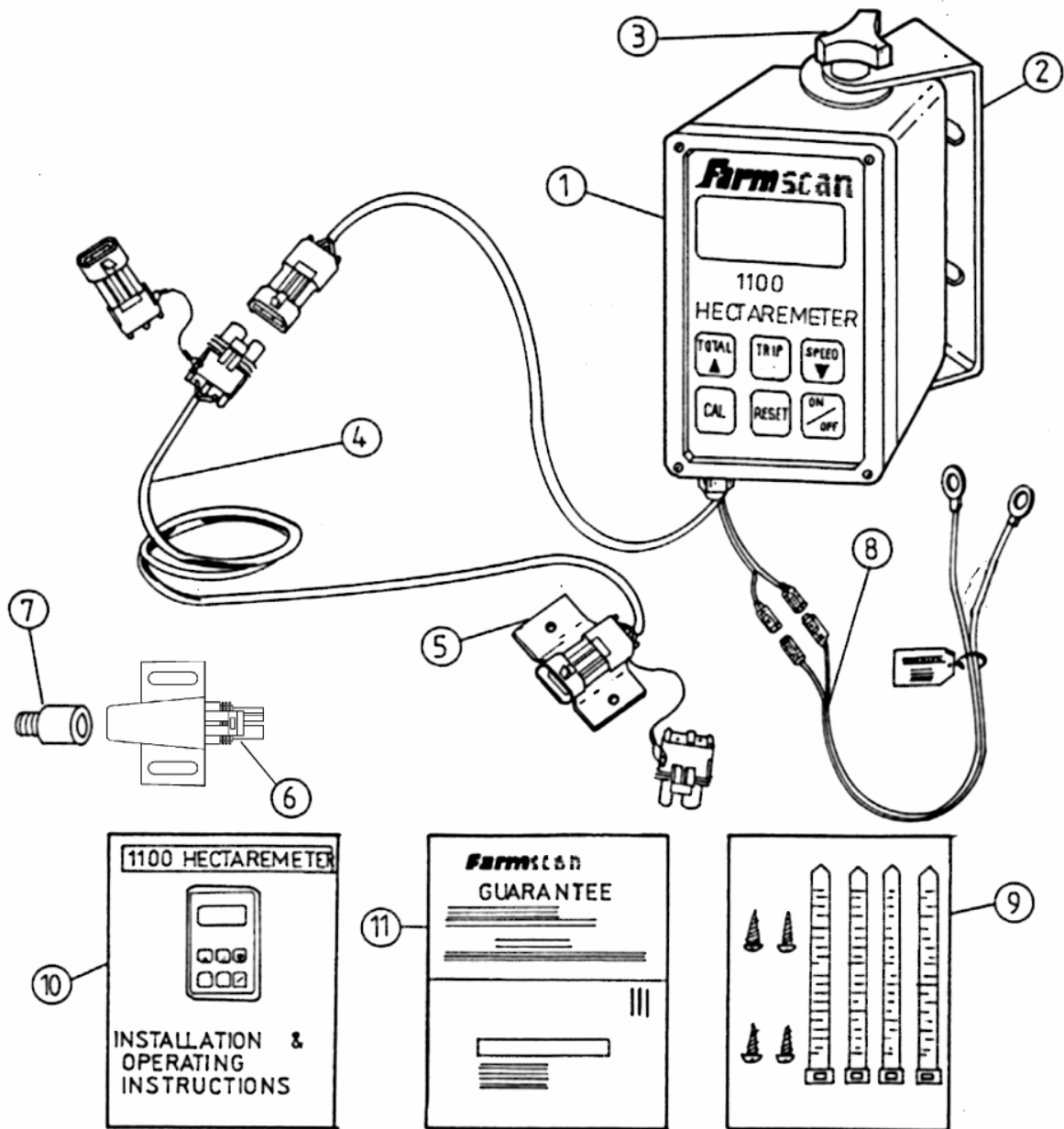

GENERAL INFORMATION

The 1100 Areameter is designed to fit virtually any farm tractor or implement to record both TOTAL and TRIP hectares and to display working SPEED (K.P.H.).

The Reed Type Wheel Sensor and Magnet must be fitted to any undriven ground wheel.

If you fit the sensor to a driven wheel, the speed and hectare readings will be wrong if wheel slippage occurs.

The sensor is best fitted to the front wheel of a 2 WD tractor or to an implement wheel when installed on a 4WD or front assist tractor.

Another alternative is to use the REED TYPE SENSOR together with a SHAFT MAGNET (AA-117) onto a metering shaft driven off the ground wheel of an implement.

The 5 metre Sensor Cable supplied, will reach the front wheel of a 2 WD tractor or may be extended to reach an implement wheel by using an optional 5 or 10 metre sensor cable as an extension.

OPTIONAL :	AC-205	5m	2 WAY SENSOR CABLE
	AC-210	10m	2 WAY SENSOR CABLE

If using the sensor cable as an extension to the rear of the tractor, use the cable mounting bracket (Ref 5 on parts table) to secure the connector away from hydraulic contamination and make sure dust caps are installed when cable is not being used. Dust caps should be plugged together when the cable is in use, to ensure they also stay clean.

The Areameter may also be used to measure DISTANCE by entering a WIDTH factor of 10.00m. The TOTAL and TRIP readout will then display DISTANCE in (Km).

eg. TOTAL Kilometres

NOTE: In very cold conditions, the display digits may appear to change slowly, but this will not affect the accuracy of the meter.

AREAMETER INSTALLATION

The Areameter Unit is not waterproof and therefore must be installed in a tractor cab or must be protected against moisture. The warranty does not cover moisture damage.

OPTIONAL :	AH-500 WEATHER COVER
	AH-480 KEYPAD MEMBRANE

Use the bracket and securing knobs supplied to mount the unit in a convenient location.

POWER CONNECTION

Do not connect power until all other installation is complete.

The 8 metre POWER CABLE must be connected DIRECT to 12 volt DC vehicle battery terminals.

DO NOT join power cable with any other electrical equipment or the vehicle chassis, this may cause interference.

USE cable ties supplied to secure power cable away from risk of damage.

Connection to battery terminals must be clean and tight.

WARNING - Disconnect power cable from battery when arc welding on machinery as damage to the unit may result.

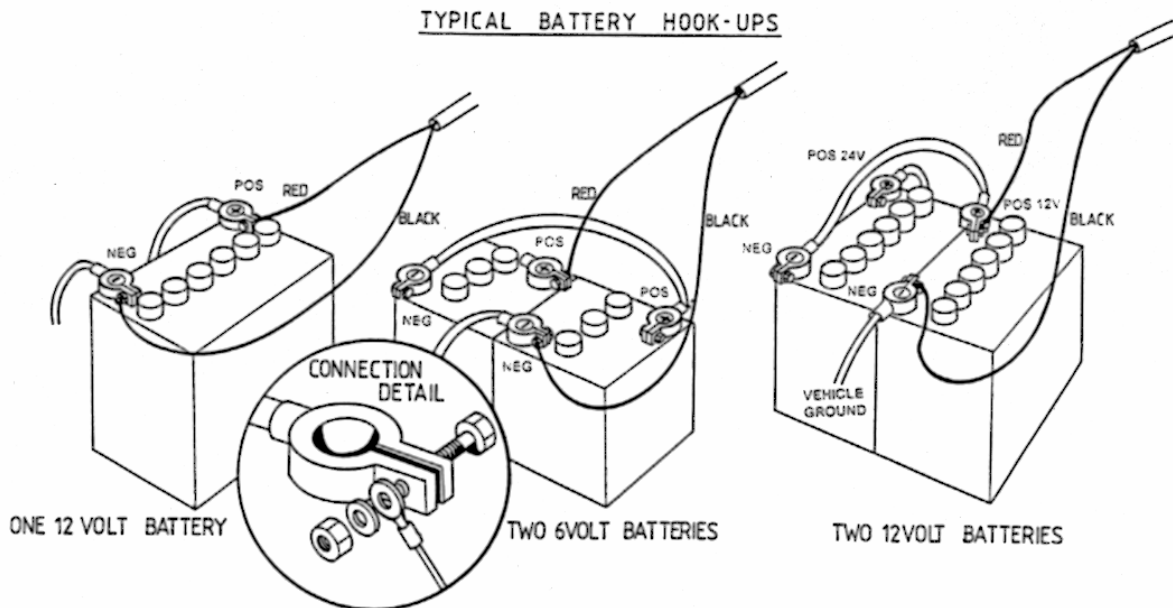

WHEEL SENSOR INSTALLATION

The magnet, fitted to the wheel must sweep past the sensor once per rotation as shown, with a clearance of 15-20mm. Do not use substitute magnets.

The sensor and magnet must face end to end.

Locate the magnet as near to the hub as possible to gain maximum ground clearance. If unable to bolt magnet through hub, it can be screwed into a M8 tapped hole or screwed into the nut brazed onto the hub. If the bolt in the magnet is too long or short it can be replaced with a M8 bolt to best suit.

If mounted onto a steered wheel be sure the sensor moves on the same axis as the wheel to maintain equal clearance when turning and ensure cable is not pulled tight when turned from lock to lock.

As the sensor is not affected by moisture or mud the main precaution is to protect the sensor and cable from physical damage. As a precaution, keep the wheel sensor cable away from, aerial leads, engine kill switch cable or wires to electronic clutches and solenoid valves. Use cable ties supplied to secure sensor cable and connect into Areameter Unit.

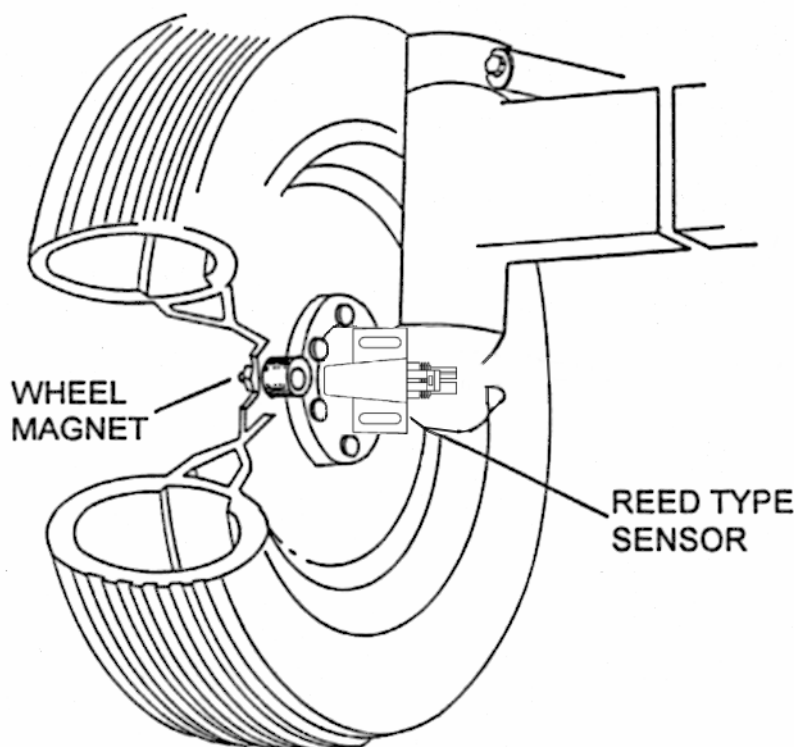

SHAFT SENSOR INSTALLATION

The magnet, fitted to the shaft must sweep past the sensor once per rotation as shown, with a clearance of 10 - 15mm. Do not use substitute magnets.

Clamp the shaft magnet (part No. AA - 117 obtainable from your local Farmscan dealer or authorised service agent) around a shaft or lock collar, which is driven by a ground wheel. The clamp is adjustable from 19 - 38mm in diameter. The magnet may be transferred to a larger clamp if necessary.

The sensor and magnet must face end to end.

As the sensor is not affected by moisture or mud the main precaution is to protect the sensor and cable from physical damage. As a precaution, keep the shaft sensor cable away from, aerial leads, engine kill switch cable or wires to electronic clutches and solenoid valves. Use cable ties supplied to secure sensor cable and connect into Areameter Unit.

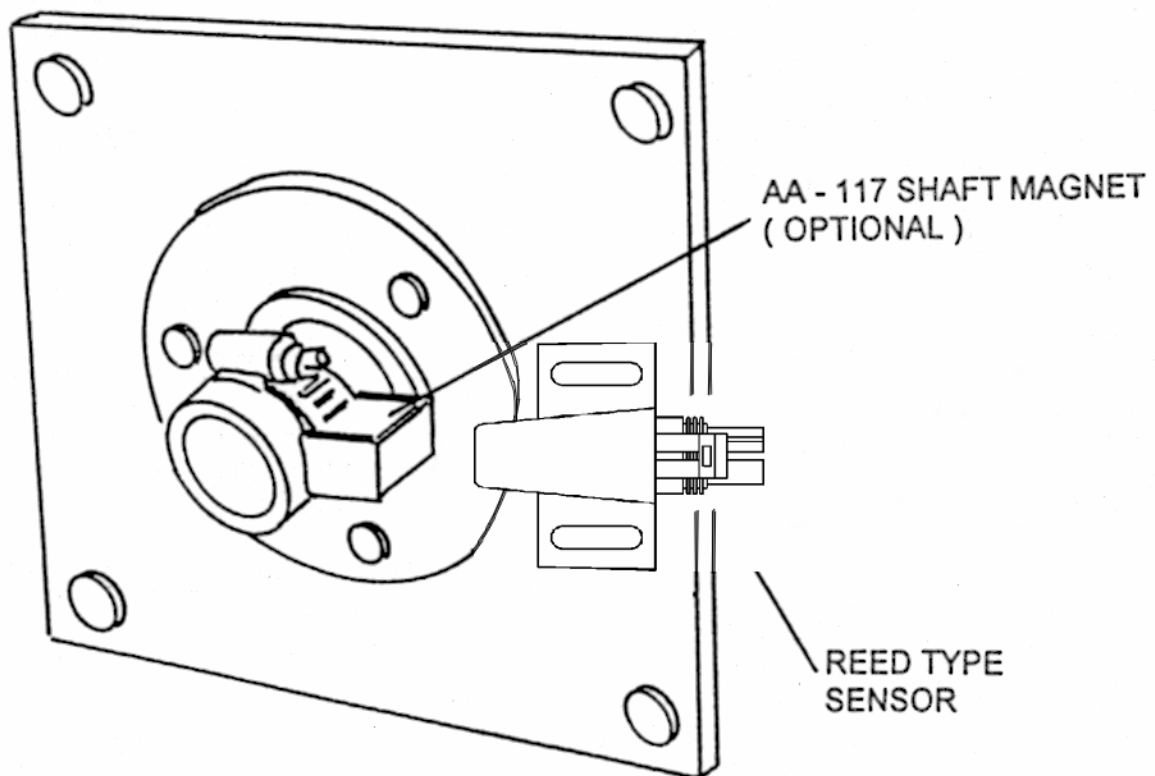

OPERATION

ON/OFF KEY: The ON/OFF key toggles the Areameter power ON or OFF. Whenever the unit is switched ON the TOTAL hectares will be displayed first.

eg. 62.75 TOTAL HECTARES

From this point you can select any other key.

TRIP KEY: Displays the TRIP hectares, works just like a car trip meter. You can reset the TRIP hectares for each paddock or load without losing the TOTAL hectares.

Maximum trip reading is 999.9 hectares.

Resolution is 00.00 to 99.99 then 100.1 to 999.9 hectares.

NOTE: With certain distance and width factors the display appears to count incorrectly, skipping numbers. However, internally the display is calculating the exact area covered given the calibration factors entered and will not effect the accuracy of the meter.

TOTAL KEY: Displays the TOTAL hectares which can be reset at any time, without losing TRIP hectares.

Maximum total reading is 9999 hectares.

RESET KEY: After selecting either TOTAL or TRIP hectares, hold the RESET key down for approx. 3 seconds to clear either readout back to zero.

SPEED KEY: Displays the working SPEED (KPH) at any time whilst travelling.

eg. 12.6 KPH

MEMORY: Both TOTAL and TRIP area readings are automatically stored in permanent memory every 6 minutes of operation or when the unit is switched OFF using the ON / OFF key.

The last 6 minutes of operation will be lost from memory if power is interrupted from source without first switching the unit off at the ON/OFF switch.

FLASHING

DECIMAL POINT: The decimal point on the display will flash for each pass of the magnet to indicate that the sensor is working. When fitted to a metering shaft this may be used to indicate the shaft is turning.

HOLD FACILITY

To stop the Areameter when travelling to refill, either switch the unit off or fit an optional STANDBY SWITCH to interrupt one of the sensor wires.

Farmscan can provide either a MECHANICAL or ELECTRONIC STANDBY option to automatically stop the area meter counting.

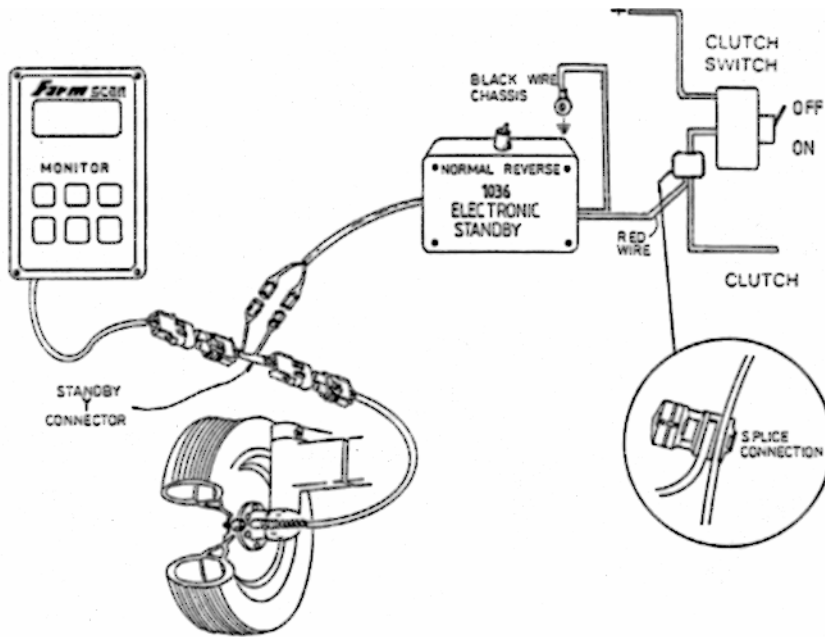

The 1036 ELECTRONIC STANDBY connects to any existing switch that is turned on or off when the machine is engaged (eg. clutch switch).

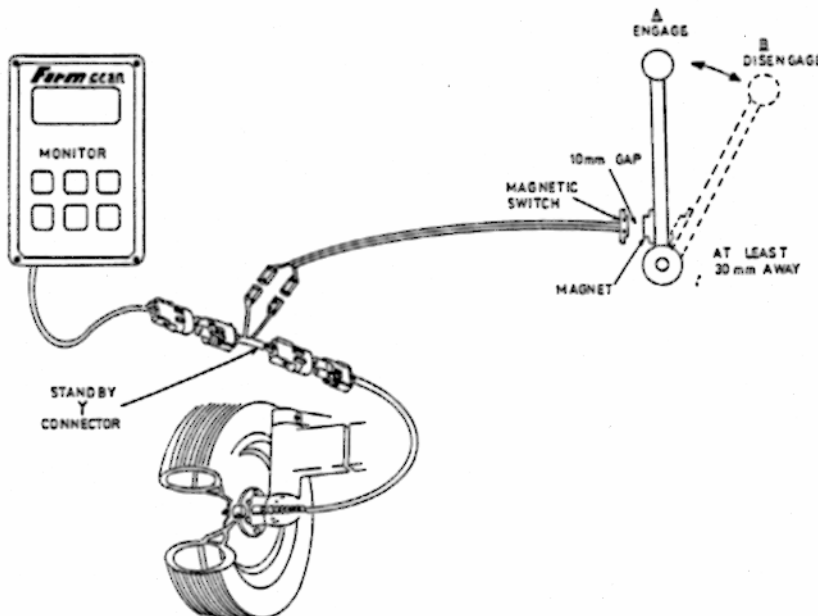

The 1037 MECHANICAL STANDBY connected to any mechanical device that is moved from one position to another (eg. engage lever).

CALIBRATION

The Areameter must be calibrated to suit the machinery WIDTH and DISTANCE travelled per pulse from the wheel / shaft sensor.

CALIBRATION WARNING

WIDTH and DISTANCE calibration factors are permanently stored in memory whenever the CAL routine is completed as explained on page 9.

If calibration factors are corrupted due to outside interference the readout will display HELP to indicate that calibration factors must be checked.

DISTANCE MEASUREMENT PROCEDURE (WHEEL SENSOR)

1. Align the wheel magnet and sensor.
2. Mark bottom centre of tyre on which the sensor is fitted and peg ground in corresponding position.
3. Move slowly forward and stop on exactly 10 tyre rotations.
4. Measure overall distance travelled and divide by 10 to get an average.

$$\begin{array}{rcl} \text{eg.} & 10 \text{ TURNS} & = & 23.45 \text{ METRES} \\ & 23.45 \div 10 & = & 2.345 \text{ METRES / TURN} \end{array}$$

Therefore distance calibration factor = 2.345 meters.

DISTANCE MEASUREMENT PROCEDURE (SHAFT SENSOR)

1. Align the shaft magnet and the sensor.
2. Peg the ground at the base of any tractor or implement wheel.
3. Move slowly forward and count exactly 10 rotations of the shaft.
4. Peg the ground again, at the base of the same wheel and measure the distance travelled. Divide the distance travelled by 10 to get an average.

$$\begin{array}{rcl} \text{eg.} & 10 \text{ TURNS} & = & 23.45 \text{ METRES} \\ & 23.45 \div 10 & = & 2.345 \text{ METRES / TURN} \end{array}$$

Therefore distance calibration factor = 2.345 meters.

ENTERING DISTANCE & WIDTH CALIBRATION FACTORS

1. Switch Areameter ON and press CAL key to display H1 (Distance Calibration Factor).

eg.

2. Use UP or DOWN arrow keys to set distance factor in millimetres.

ie. 2.345 metres = 2345 millimetres

eg. MILLIMETRES

3. Press CAL key again to display H2 (Width Calibration Factor).

eg.
 METRES

4. Measure effective implement WIDTH in metres and use UP and DOWN keys to set width factor.

eg. METRES

5. Press CAL key again to EXIT calibration routine and store new calibration factors in memory.

NOTE : To change WIDTH factor for different implements, press CAL key twice to skip past HI and change H2 using the UP / DOWN keys then press CAL again to finish.

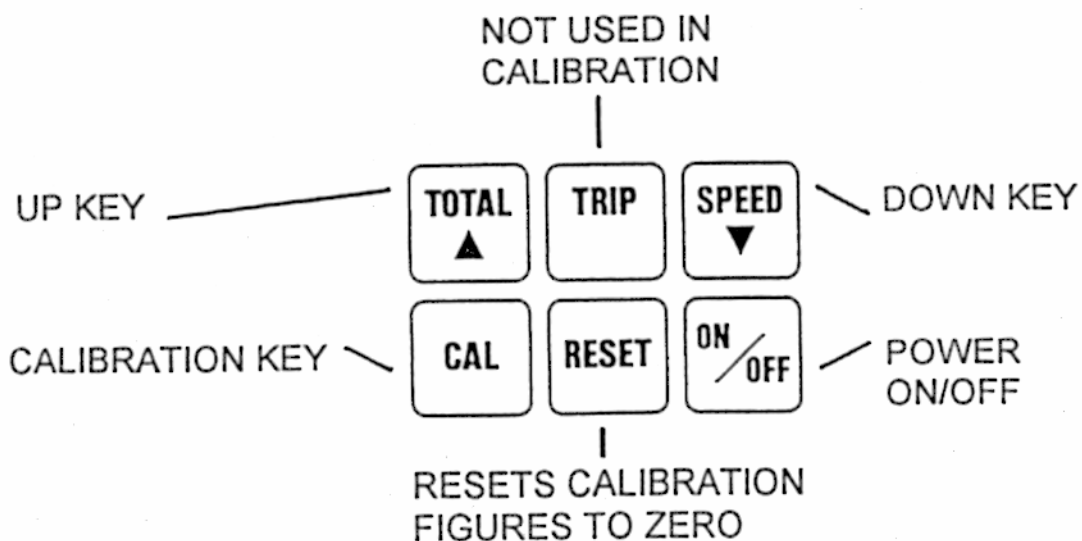

TROUBLESHOOTING

PROBLEM	POSSIBLE CAUSE / REMEDY
1. NO RESPONSE FROM ON / OFF SWITCH	<ul style="list-style-type: none"> a) Check that power cable connections at battery, are clean and tight. b) Measure voltage from power cable at monitor connection point, is it 12 - 13.8 V DC ? c) If voltage OK and unit fails, return to your nearest Farmscan dealer or authorised service agent.
2. HECTARES TALLY WRONG	<ul style="list-style-type: none"> a) Check that H1 and H2 calibration factors are measured and set correctly. b) Is machine overlapping or underlapping ? c) Is the unit counting headlands ? - Fit a Standby option see page 7. d) Switch to SPEED readout and make sure reading is constant at a constant speed. Could be cable or sensor damage if speed readout is jumpy. e) Is the magnet and sensor facing end to end ? f) Is the proper magnet being used ? g) Is the magnet too far away from sensor ? (15-20 mm gap with wheel magnet or 10 - 15mm with shaft magnet). h) Is the magnet staying in line with sensor on corners ? i) Is the wheel loose ? j) Is the sensor on a non driven wheel / or a shaft driven by a wheel? - Tractor drive wheels cause over reading. k) Replace wheel / shaft sensor, if none of the above.
3. DECIMAL POINT WILL NOT FLASH	<ul style="list-style-type: none"> a) This is normal operation if the TOTAL hectares being displayed is greater than 999.9 , or it is extremely cold.
4. HECTARES OR SPEED DOESN'T WORK	<ul style="list-style-type: none"> a) Your speed must be above 2.0 K.P.H. for it to register, however area registers at any speed. b) Check that H1 and H2 calibration factors are properly entered. c) Check magnet and sensor are properly aligned with a 15 - 20mm gap. d) If using a Standby option, disconnect standby from sensor cable and reconnect cable as normal to isolate if standby malfunction is the cause. e) If still no response follow SENSOR & CABLE TEST PROCEDURE page 11.

TROUBLESHOOTING

PROBLEM		POSSIBLE CAUSE / REMEDY
5.	TRIP OR TOTAL HECTARES DON'T RESET	a) Press TOTAL or TRIP key first to select area to be cleared. Reset key must be pressed and held down for at least 3 - 4 seconds. b) c) If hectares still don't reset, return unit to your nearest Farmscan dealer or authorised service agent.
6.	HECTARES COUNT UP ON THEIR OWN WITHOUT MOVING	a) Switch off all other electronics to eliminate electrical interference as the cause. If switching off electronics eliminates the fault, ensure that the Areameter cables are not running alongside wiring from other electronic devices, and / or physically move the position of the Areameter in relation to the other equipment. b) If petrol engine in close proximity, stop engine to see if interference is caused by engine ignition system. NOTE: Carbon ignition leads must be fitted to spark plugs and coil to stop interference. c) Disconnect sensor from cable at wheel / shaft. If problem stops, replace sensor. d) Make sure Areameter has independent power cable, wired direct to battery +/- terminals. e) If unit still counts hectares, return unit to your local Farmscan dealer or authorised service agent.
6a	CALIBRATION FIGURES KEEP CHANGING	

SENSOR & CABLE TEST PROCEDURE

1. Switch Areameter ON.
2. Check that H1 and H2 calibration factors are entered correctly.
3. Press SPEED key. Display should read 0.0
4. Disconnect sensor from cable, at the sensor itself.
5. Use a pair of long nose pliers and intermittently short the pins of the connecting plug on the cable together. The speed readout should show random numbers. If speed readout responds, then replace sensor.
6. If no response, reconnect sensor and repeat test at tractor breakaway plug (if used).
 At this point if the speed responds, then the cable between the breakaway plug and the sensor is at fault.
 If still no response at tractor breakaway plug, repeat test at connection directly into the Areameter unit.
7. If no response directly into Areameter then return unit to your nearest Farmscan dealer or authorised service agent.

MULTIMETER TEST

REED TYPE SENSOR

1. Disconnect sensor from cable.
2. Rotate the shaft / pulley so that the magnet is as close as possible to the sensor.
3. Measure the resistance of the sensor, it should be a short circuit.
4. Rotate the shaft / pulley so that the magnet is as far as possible from the sensor.
5. Measure the resistance of the sensor, it should be an open circuit.

SENSOR CABLE

1. Disconnect Hectaremeter and Sensor from sensor cable.
2. Place a sturdy wire link across the two terminals at the Areameter end of the cable.
3. Measure the resistance across the two terminals at the sensor end, it should be a short circuit.

If the above is true, then the sensor cable is O.K. (skip the following points).

If the above is not true then there is a fault in the cable.

4. Check that any breakaway connections in between are clean and firm to connect, if loose to connect, use a small object to close the female connection slightly.
5. Physically inspect cable for damage, it may have been crushed or cut.